

Pegasus

40.25



macchine edili ed agricole
S.r.l.
d DIECI

Pegasus 40.25

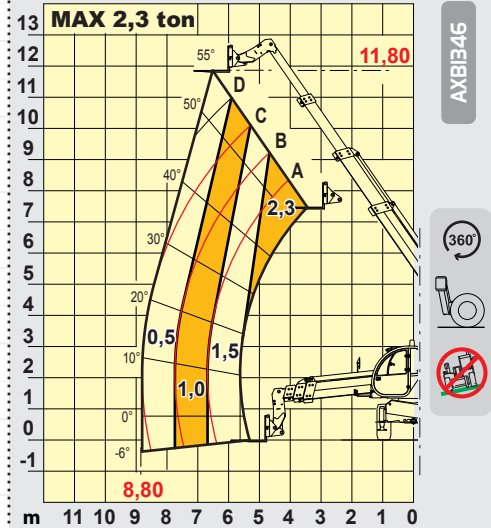
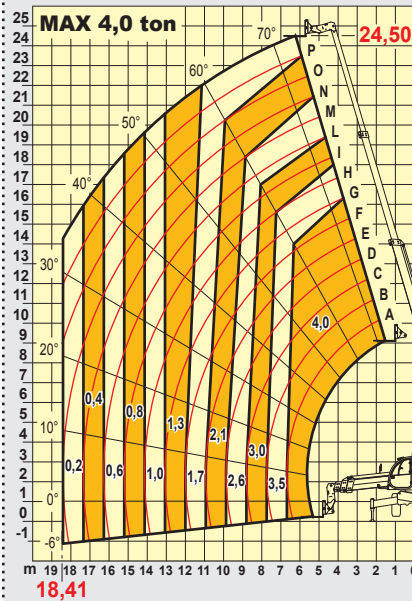
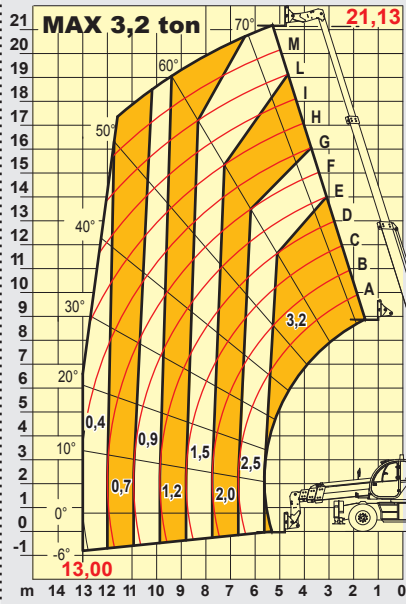

PERFORMANCES

Maximum capacity:	4.000 kg
Capacity at maximum height on stabilizers:	1.700 kg
Capacity at maximum height on tyres:	1.500 kg
Maximum capacity boom on stabilizers:	200 kg
Maximum capacity boom on tyres:	400 kg
Maximum lifting height on stabilizers:	24,50 m
Maximum lifting height on tyres:	21,13 m
Maximum horizontal boom extension:	18,41 m
Boom at maximum height:	6,63 m
Angle of fork arching:	120°
Tearing force:	5.700 daN
Towing force:	9.400 daN
Maximum slope for overtaking:	40 %
Total empty weight:	16.700 kg
Max speed:	40 km/h



ENGINE

DEUTZ BF4M2012C - TA - 103 kW	
Maximum power:	103 kW (141 hp) at 2500 rpm
Operating principle:	four-stroke engine, diesel
Cylinders number and layout:	4, vertical in line
Displacement:	4038 cm ³ -Turbo compressor aftercooler
Cooling system:	liquid



REFUELLING (litre)

Hydraulic circuit:	260
Fuel tank:	126



STANDARD DEVICES

Hydraulic movements with Danfoss proportional distributor.
 Anti-tipping device with block for hazardous movements.
 Continuous turret rotation over 360°.
 Oscillation block on rear axle.
 Hydraulic socket for possible accessories on boom head.
 Closed soundproof homologated cab FOPS, with heating.
 Stabilizers.



TYRES

Tyres:	18 - R 22,5"
--------	--------------



OPTIONAL AND ACCESSORIES

Optional and Accessories:..... see the relevant catalogue.



TRANSMISSION

Transmission:..... Hydrostatic with variable capacity pump
 Hydraulic engine:..... with automatic change
 Gear reversing:..... Electro - hydraulic
 Inching pedal for controlled forward movement
 2 speed power steering.



HYDRAULIC CIRCUIT

Gear pump with capacity at speed:	135 lt/1'
Max working pressure:	230 bar
Distributor controls with joystick:	5 in 1 proportional



DIFFERENTIAL AXLES

Steering axles:..... 2, with epicycloidal reduction gears
 Type of steering:..... 4 wheels / transversal / 2 wheels
 Front axle:..... levelling
 Rear axle:..... oscillating (possibility to block it)
 Service brake:..... oil bath on 4 wheels double hydraulic circuit, parking brake

Negative parking brake.

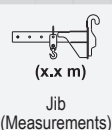
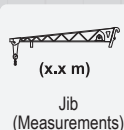
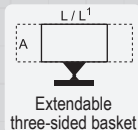
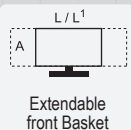

SYMBOLS KEY

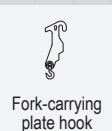
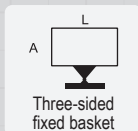
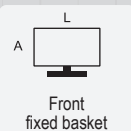

Equipments

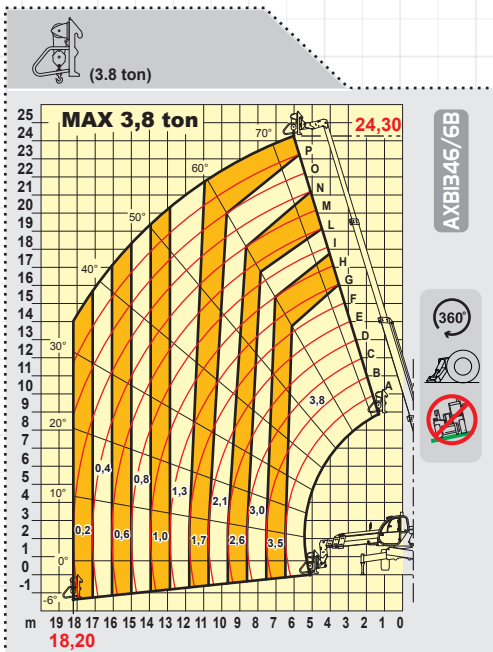
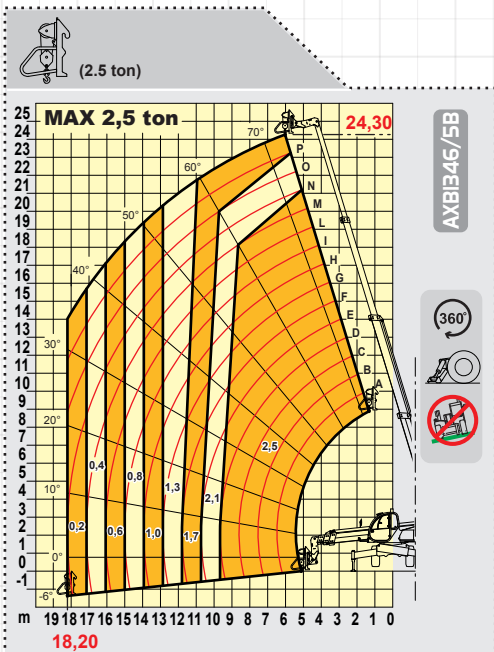
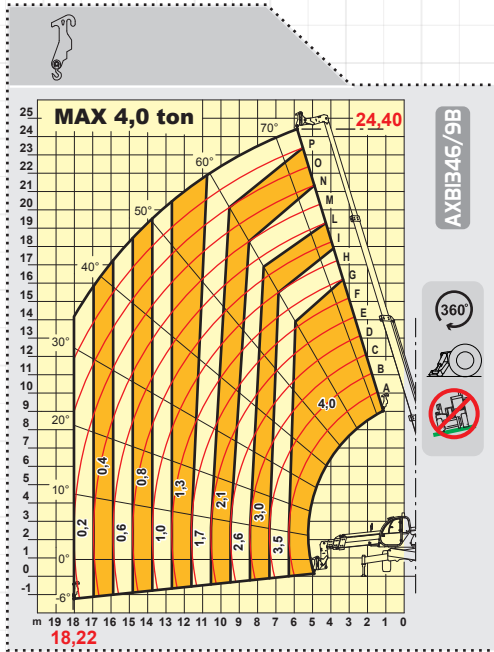
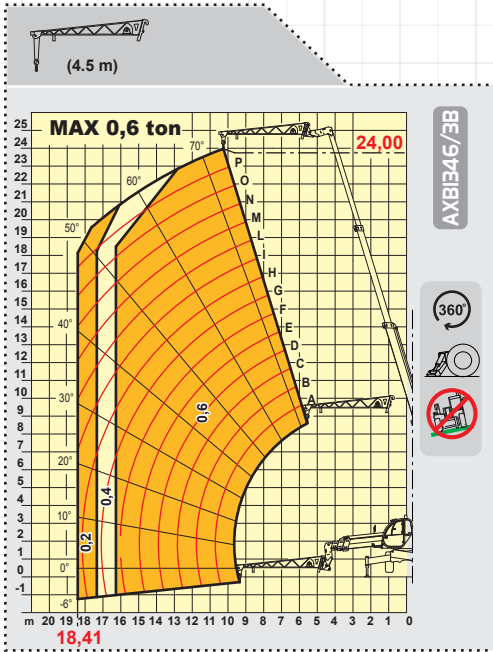
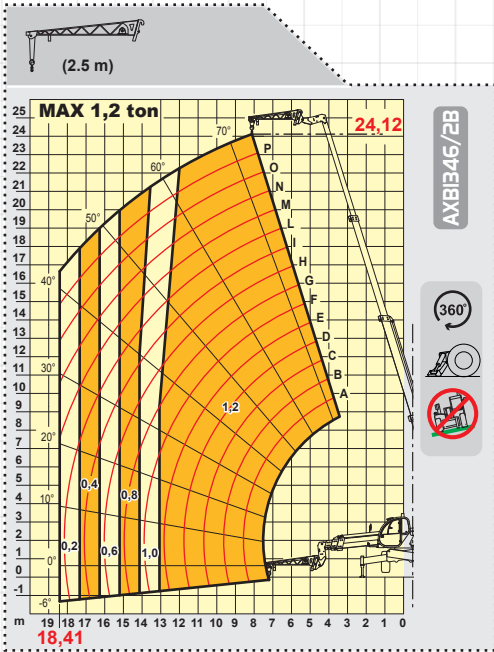
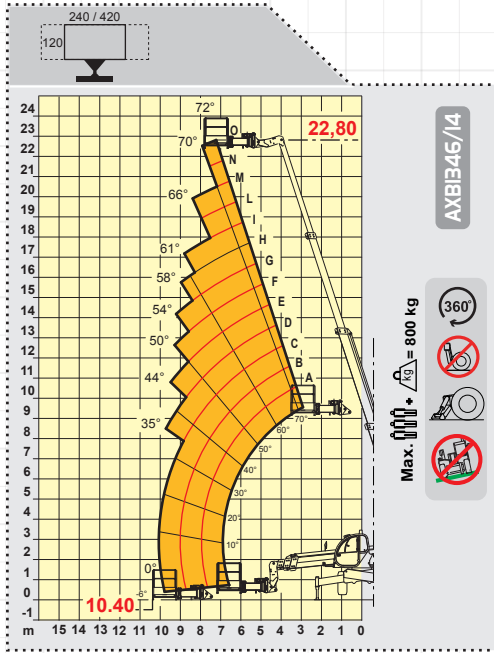
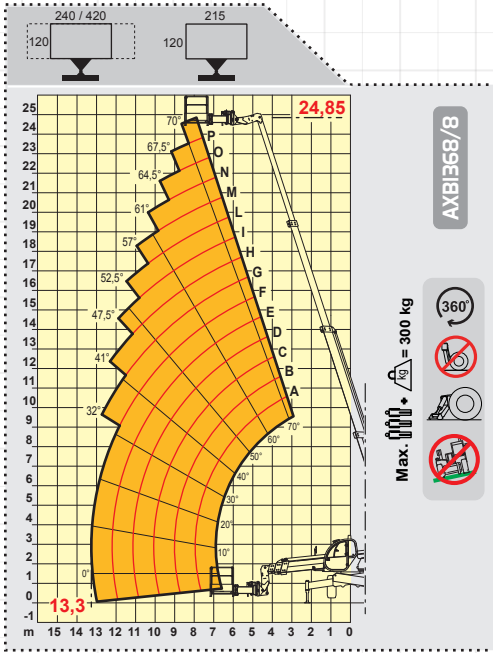
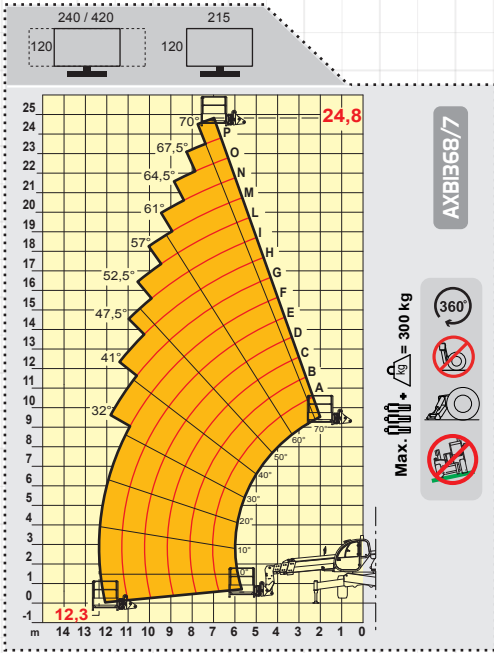

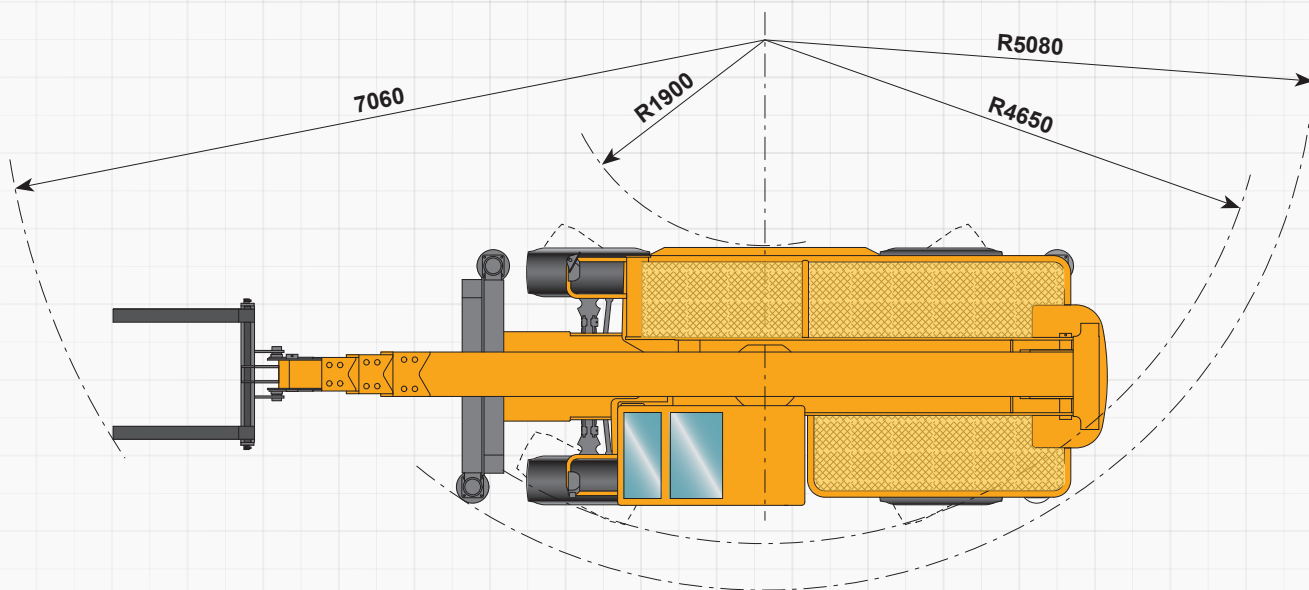
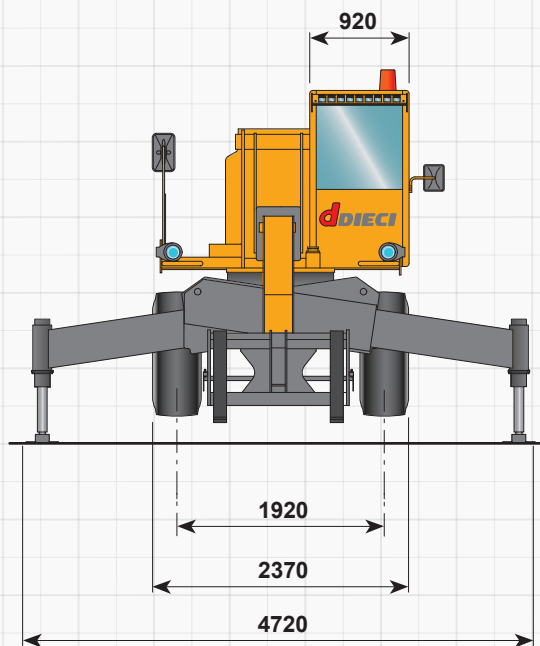
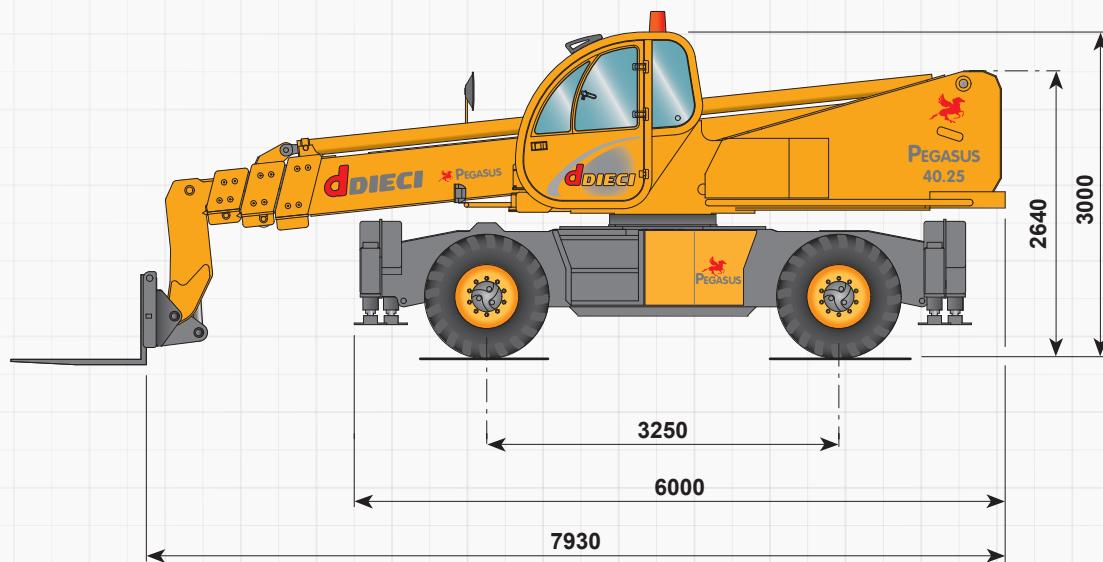

I dati contenuti in questo stampato sono forniti a titolo indicativo; i modelli descritti sono suscettibili di modifiche, senza preavviso, da parte del costruttore, disegni e fotografie possono riferirsi a equipaggiamenti opzionali o ad allestimenti destinati ad altri paesi. Per ogni altra informazione, rivolgersi alla sede DIECI all'indirizzo a fondo scheda.
 The information contained in the present publication are only intended as an indication; the models described may be modified, without notice, by the manufacturer, drawings and photographs may refer to optional equipment or to particular specifications for other countries. For any further information, please contact DIECI headquarters at the address given below.

(Cod. AXE3093 - 3/2006 v0)

DIECI S.r.l.
 Via E. Majorana, 2/4 - 42027 Montecchio Emilia (RE)
 Tel. +39 0522 869611 - Fax +39 0522 869744
 www.dieci.com - mailbox@dieci.com

